

When booting FPGA from RPI, MISO and MOSI switch. Send bitstream out MISO0. This requires bitbanging the SPI stream. Keep SPI\_CS low when driving CRESET high.

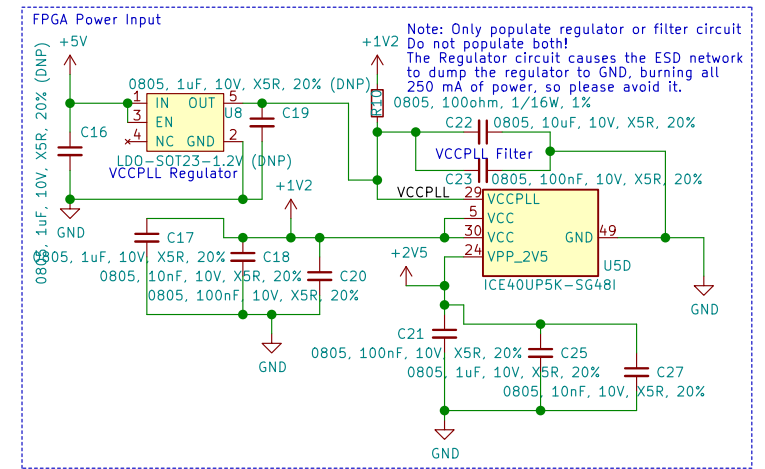
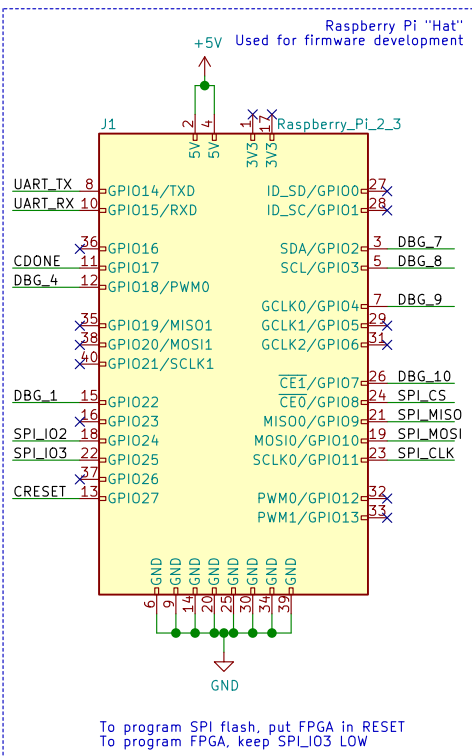
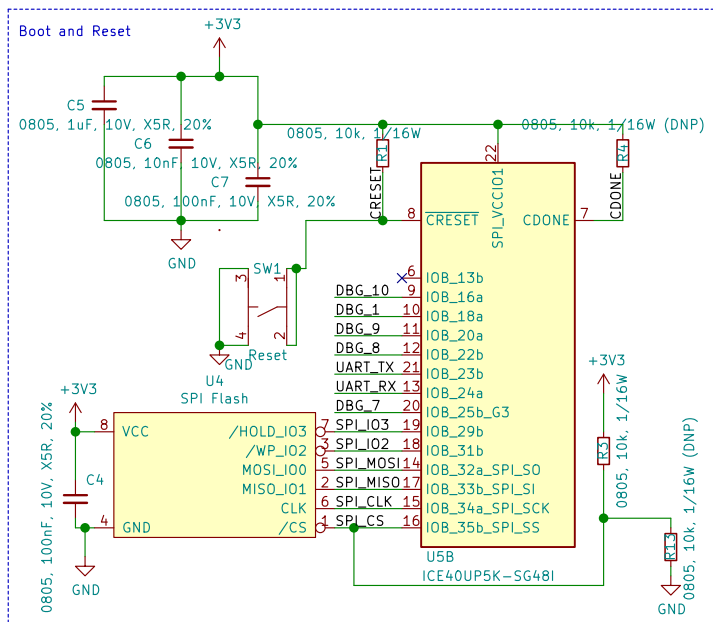
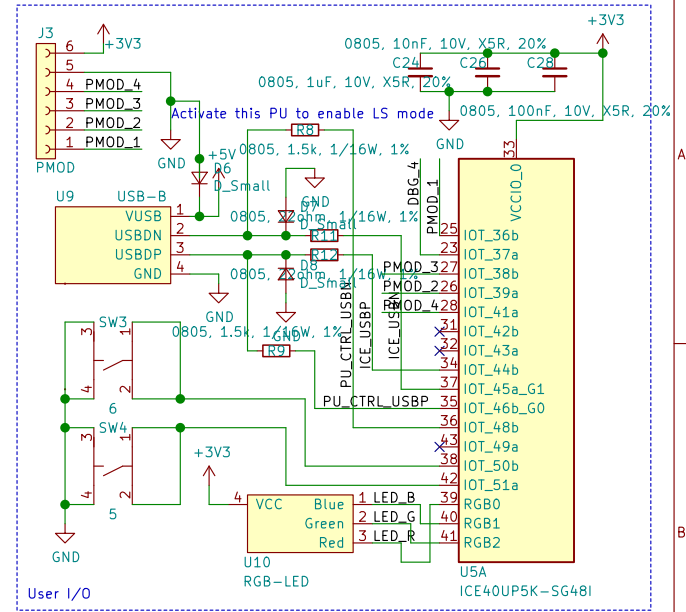

Stretch PCB for electrical verification  
**Foosn PTE Ltd.**

Sheet: /  
 File: tomu-fpga.sch

**Title: Tomu FPGA**

Size: A4 Date: 2018-11-23  
 KiCad E.D.A. kicad (5.0.0)

Rev: EVT2  
 Id: 1/1